

Conveyor system FB-295

F45

FT

FS

FL

FLP

F65

FM

FMP

F85

F85P

FH

FK

FKP

FB140

FB175

FB295

SPIRAL

FW

FLX

FMX

FHX

FBX175

FBX295

ACC

CA

FC

TOOL

IDX

Contents

Chains 3

Conveyor beam 4

End drive units 6

Idler unit 8

Horizontal plain bends 10

Vertical bends 12

Chains



Chains

			F45
<i>Plain chain</i>			FT
FBTP 3A295	Plain chain Length 5 mt		FS
FBTL 295	Plain link		FL
			FLP
<i>Friction top chain</i>			F65
FBTP 3A295F	Plain chain Length 5 mt		FM
FBTL 295F	Plain link		FMP
			F85
<i>Plain chain</i>			F85P
FBTP 3A295A	Plain chain Length 5 mt		FH
FBTL 295A	Plain link		FK
			FKP
<i>Friction top chain</i>			FB140
FBTP 3A295AF	Plain chain Length 5 mt		FB175
FBTL 295AF	Plain link		FB295
			SPIRAL
<i>Tools and accessories</i>			FW
FBTT 13X16	Plastic pivot		FLX
FMTT 13X16	Plastic pivot		FMX
FMTD 6X50	Steel pin		FHX
FBMJ 6P	Pin insertion tool		FBX175
FBMJ 6	Pin insertion tool		FBX295
FDSS 450	Silicone-based lubricant	ACC	
			CA
			FC
			TOOL
			IDX

Conveyor beam

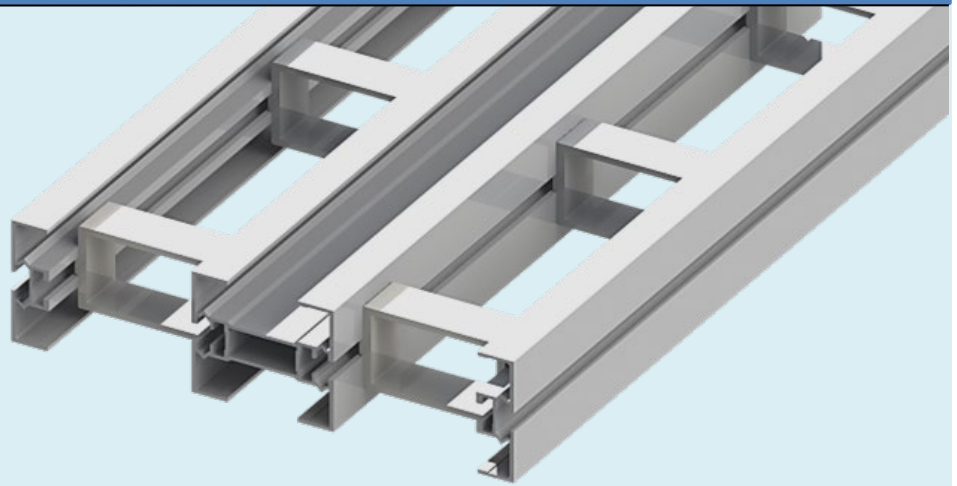

Beam

FBCB 3A295

Length 3 mt

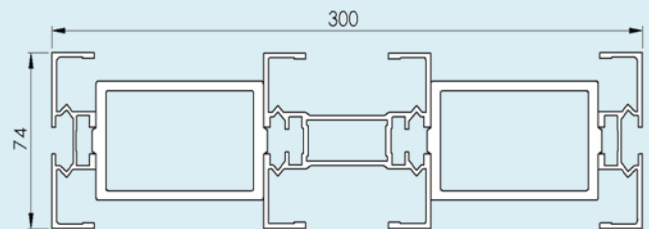

FBCB 3A85

Length 3 mt

FBCB 3AH

Length 3 mt

FBCE 85

Snap-fit clip kit for
outer beam

FBCB 3A H

FBCB 3A85

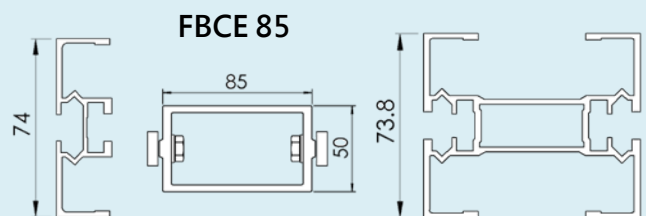

Conveyor beam

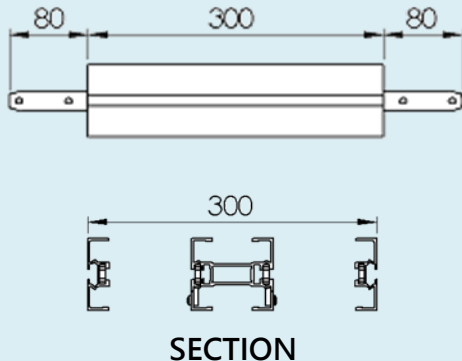
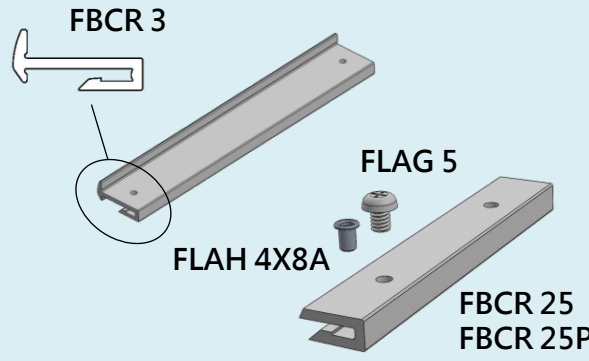
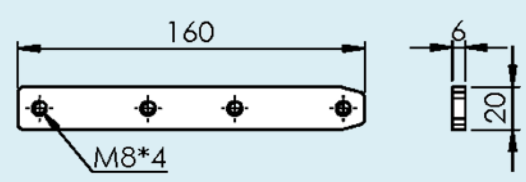
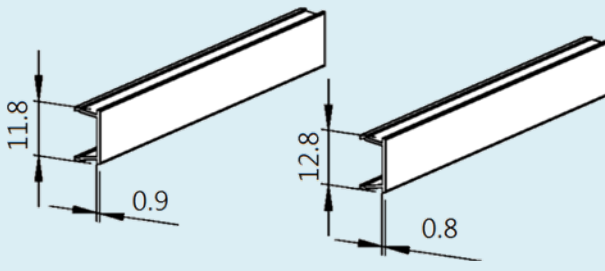
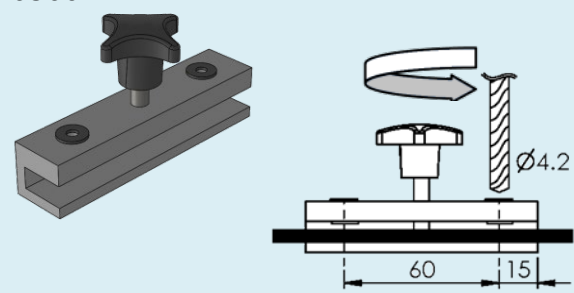
<p>Beam section for chain installation</p> <p>FBCC 300A295</p> <p>Beam section for chain installation Including connecting strips and screws</p>		<p>F45</p> <p>FT</p> <p>FS</p> <p>FL</p> <p>FLP</p> <p>F65</p> <p>FM</p>
<p>Slide rail</p> <p>FBCR 3 Length 25 m HDPE Gray-black</p> <p>FBCR 25 HDPE White</p> <p>FBCR 25P PVDF White</p> <p>FBCR 25POK POK White</p> <p>FLAH 4X8A Aluminium rivet</p> <p>FLAG 5 Plastic screw</p>		<p>FMP</p> <p>F85</p> <p>F85P</p> <p>FH</p> <p>FK</p> <p>FKP</p> <p>FB140</p> <p>FB175</p>
<p>Connecting strip with set screws</p> <p>FSCJ 6X160 H=20 mm Length 160 mm</p>		<p>FB295</p> <p>SPIRAL</p> <p>FW</p> <p>FLX</p> <p>FMX</p>
<p>T-slot cover</p> <p>FCAC 2 Aluminium Length 2 mt</p> <p>FCAC 3P Polyvinyl chloride Length 3 mt</p>		<p>FHX</p> <p>FBX175</p> <p>FBX295</p> <p>ACC</p> <p>CA</p> <p>FC</p> <p>TOOL</p>
<p>F3920500 Drill fixture for slide rail</p>	<p>F3920500</p> 	<p>IDX</p>

End drive units

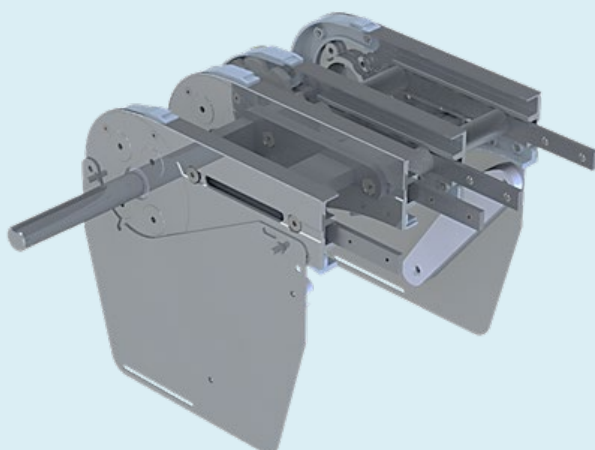

FBEB 0A300LU Basic unit
Dia. 25mm
Transmission on left-hand side

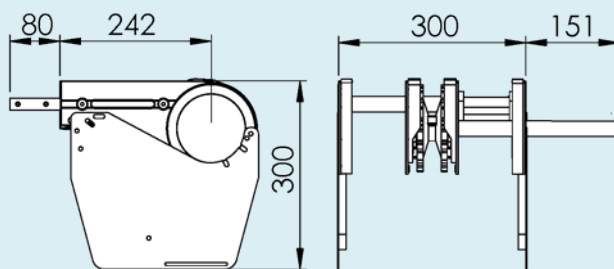

FBEB 0A300RU Basic unit
Dia. 25mm
Transmission on right-hand side

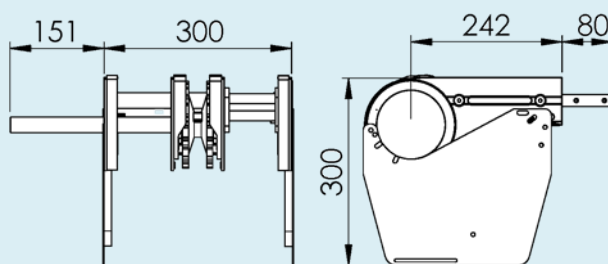

Maximum weight on conveyor : 300 kg
Maximum conveyor length : 30 M
Maximum conveyor speed : 60 M/min

End drive units

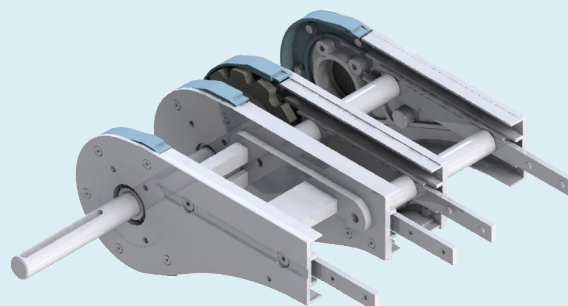

FBEB 0A300LGU Basic unit
Dia. 25mm
Transmission on left-hand side

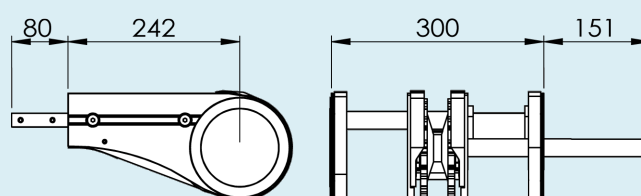

FBEB 0A300RGU Basic unit
Dia. 25mm
Transmission on right-hand side

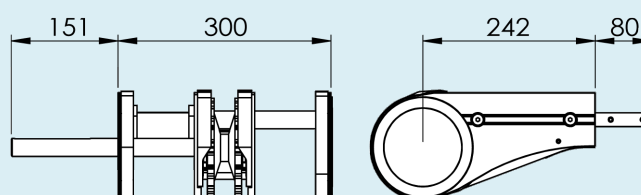

Maximum weight on conveyor : 300 kg
Maximum conveyor length : 30 M
Maximum conveyor speed : 60 M/min

- F45
- FT
- FS
- FL
- FLP
- F65
- FM
- FMP
- F85
- F85P
- FH
- FK
- FKP
- FB140
- FB175
- FB295**
- SPIRAL
- FW
- FLX
- FMX
- FHX
- FBX175
- FBX295
- ACC
- CA
- FC
- TOOL
- IDX

End drive units

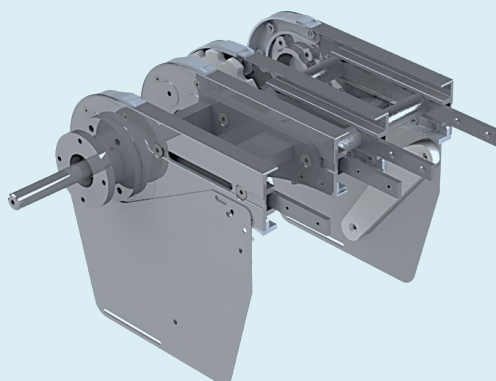

FBEB 0A300HNLP Drive unit
 Dia. 25mm to 20mm Transmission on
 left-hand side
 SEW SA37
 SEW WA 30
 SEW WA 20

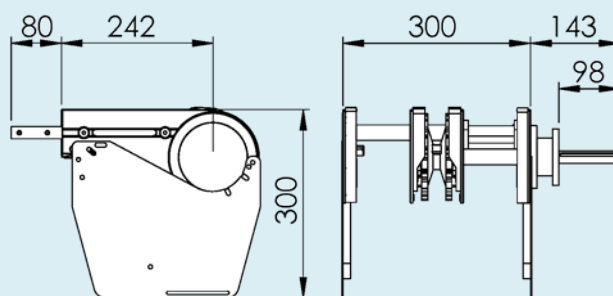

FBEB 0A300HNRP Drive unit
 Dia. 25mm to 20mm Transmission on
 left-hand side
 SEW SA37
 SEW WA 30
 SEW WA 20

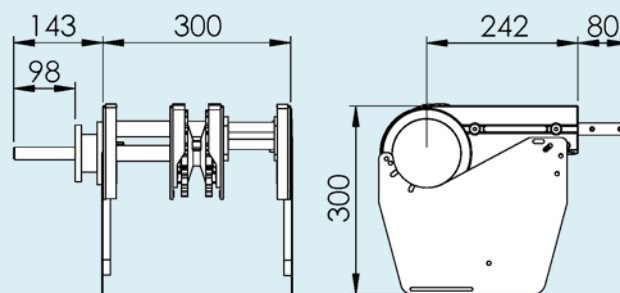

Maximum weight on conveyor : 300 kg
 Maximum conveyor length : 30 M
 Maximum conveyor speed : 60 M/min

Idler end units

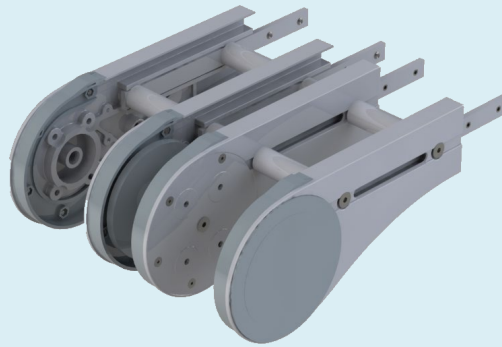

FBEJ 300

Idler end unit

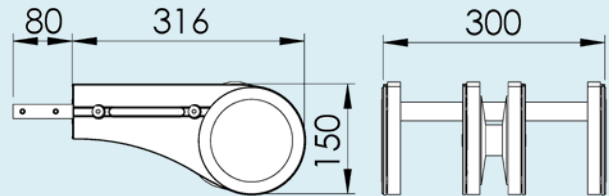

F45

FT

FS

FL

FLP

F65

FM

FMP

F85

F85P

FH

FK

FKP

FB140

FB175

FB295

SPIRAL

FW

FLX

FMX

FHX

FBX175

FBX295

ACC

CA

FC

TOOL

IDX

Horizontal plain bends

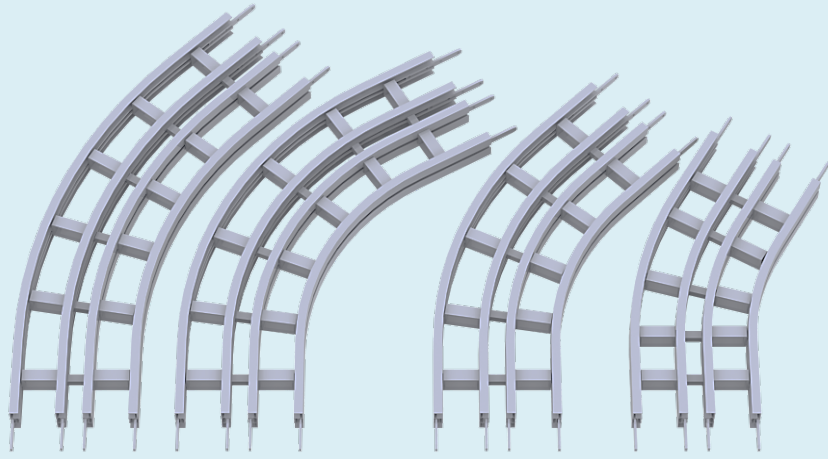

Horizontal plain bends

Horizontal plain bend, 30°
Radius to centre of beam:

FBBP 30A295R700 R=700 mm
FBBP 30A295R1000 R=1000mm

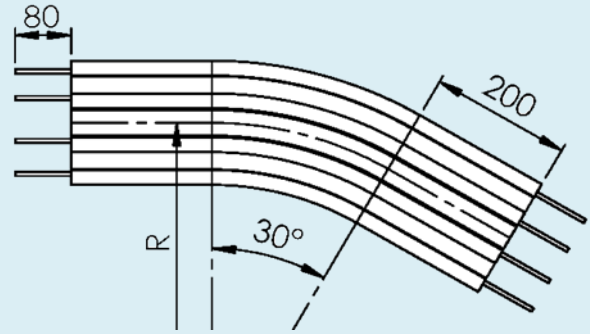

Horizontal plain bend, 45°
Radius to centre of beam:

FBBP 45A295R700 R=700 mm
FBBP 45A295R1000 R=1000mm

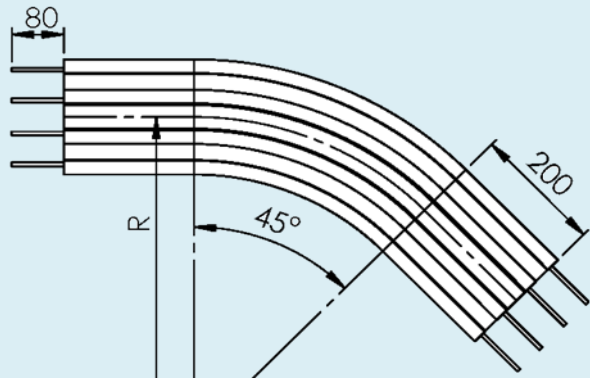

Horizontal plain bend, 60°
Radius to centre of beam:

FBBP 60A295R700 R=700 mm
FBBP 60A295R1000 R=1000mm

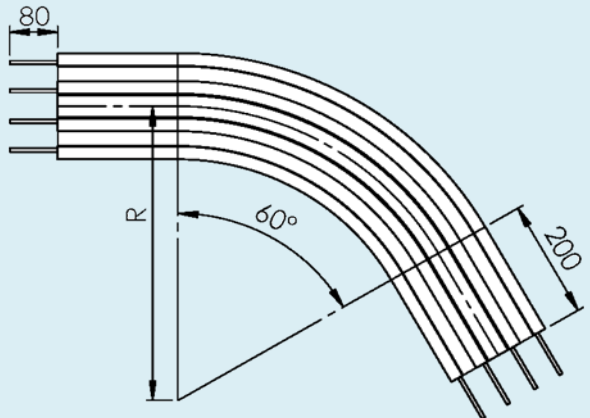

Horizontal plain bend, 90°
Radius to centre of beam:

FBBP 90A295R700 R=700 mm
FBBP 90A295R1000 R=1000mm

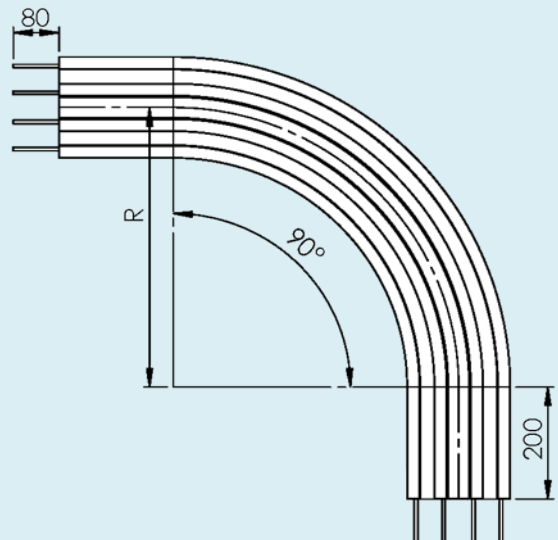

F45

FT

FS

FL

FLP

F65

FM

FMP

F85

F85P

FH

FK

FKP

FB140

FB175

FB295

SPIRAL

FW

FLX

FMX

FHX

FBX175

FBX295

ACC

CA

FC

TOOL

IDX

Vertical bends

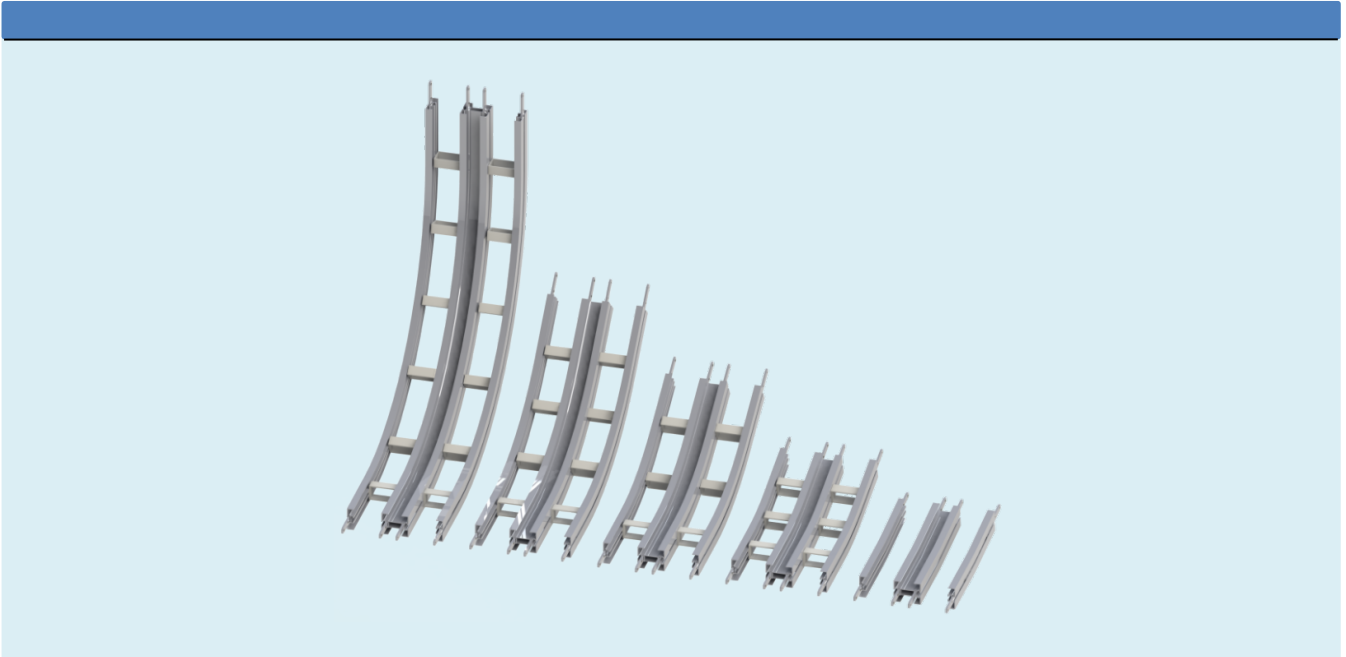

Vertical bends

Vertical bend, 5°
Radius to centre of beam:

FBBV 5A295R750 R=750 mm

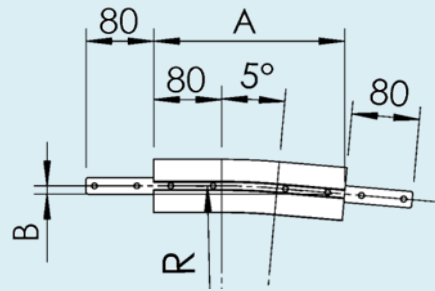

	R	A	B
FBBV 5A295R750	750	225	10

Vertical bend, 7°
Radius to centre of beam:

FBBV 7A295R750 R=750 mm

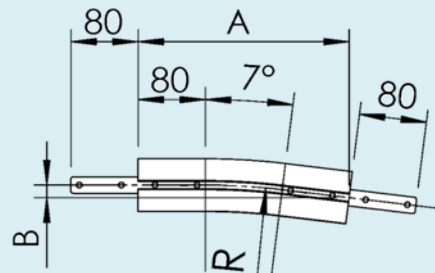

	R	A	B
FBBV 7A295R750	750	251	15

Vertical bend, 15°
Radius to centre of beam:

FBBV 15A295R750 R=750 mm

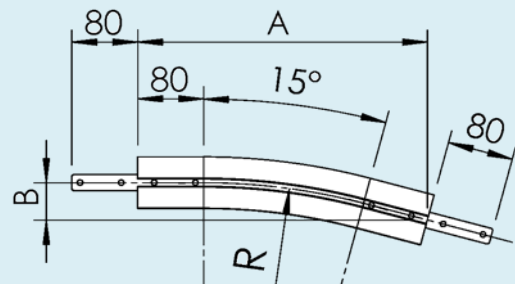

	R	A	B
FBBV 15A295R750	750	351	46

Vertical bend, 20°
Radius to centre of beam:

FBBV 20A295R750 R=750 mm

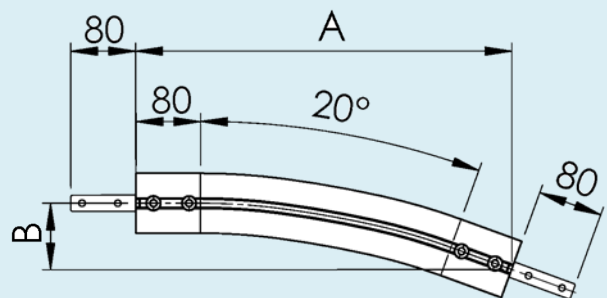

	R	A	B
FBBV 20A295R750	750	464	82

F45

FT

FS

FL

FLP

F65

FM

FMP

F85

F85P

FH

FK

FKP

FB140

FB175

FB295

SPIRAL

FW

FLX

FMX

FHX

FBX175

FBX295

ACC

CA

FC

TOOL

IDX

* Note: Special angles on request.

Vertical bends

Vertical bend, 30°
Radius to centre of beam:

FBBV 30A295R750 R=750 mm

	R	A	B
FBBV 30A295R750	750	524	141

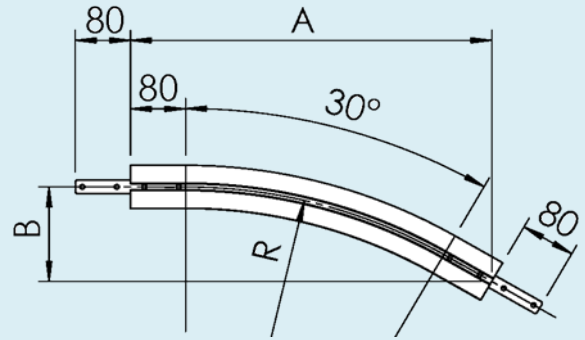

Vertical bend, 45°
Radius to centre of beam:

FBBV 45A295R750 R=750 mm

	R	A	B
FBBV 45A295R750	750	667	277

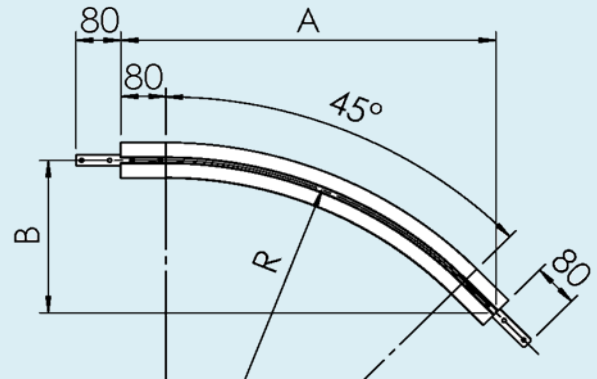

Vertical bend, 60°
Radius to centre of beam:

FBBV 60A295R750 R=750 mm

	R	A	B
FBBV 60A295R750	750	770	444

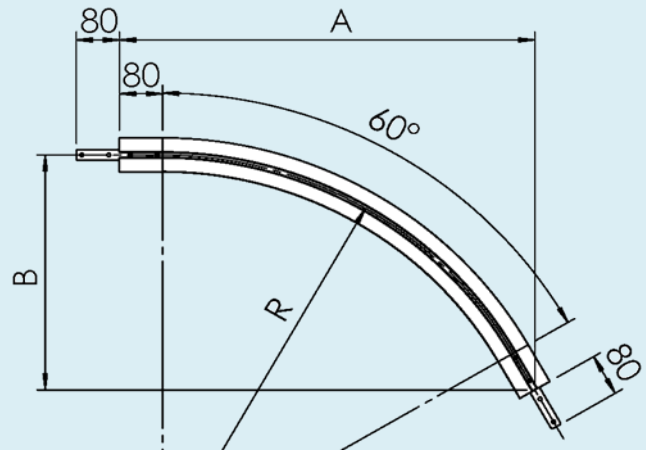

Vertical bend, 90°
Radius to centre of beam:

FBBV 90A295R750 R=750 mm

	R	A	B
FBBV 90A295R750	750	830	830

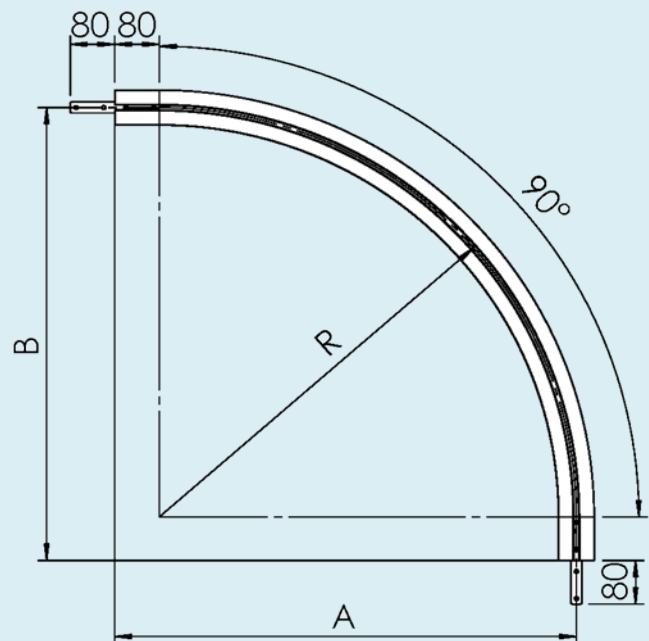

* Note: Special angles on request.

Bridge for FB295 conveyor

roller bridge

Bridge-FB295

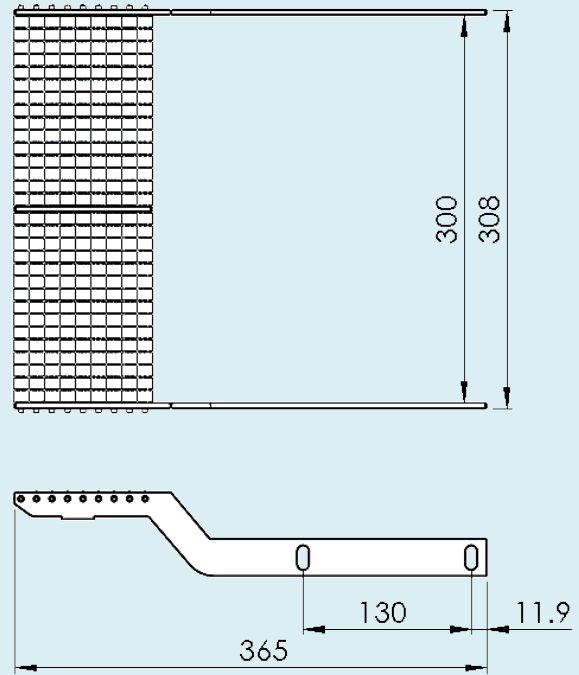

Belt bridge

FBEF 295DBL

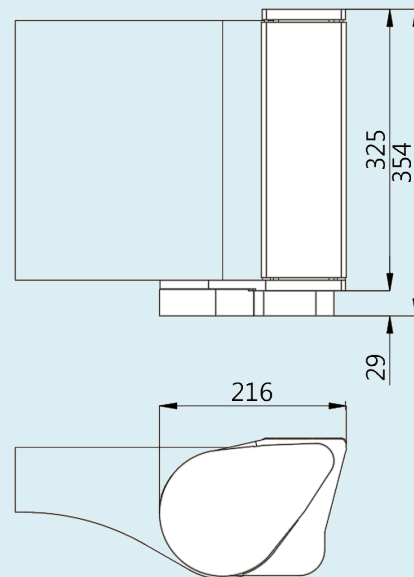

FBEF 295DBR

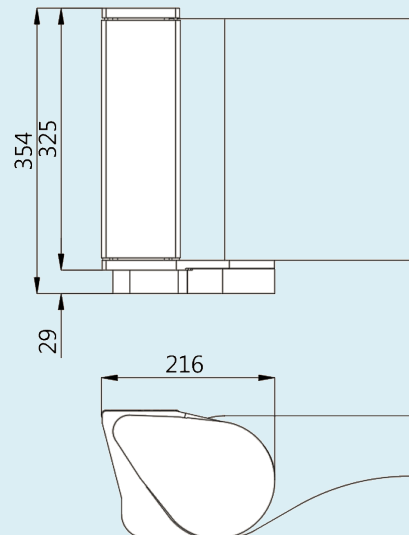

F45

FT

FS

FL

FLP

F65

FM

FMP

F85

F85P

FH

FK

FKP

FB140

FB175

FB295

SPIRAL

FW

FLX

FMX

FHX

FBX175

FBX295

ACC

CA

FC

TOOL

IDX

